

# ASCO™ Solenoid Valves

2 way, NC/NO, Direct Operated, 1/8" or 1/4" Tapped

## Features & Benefits

- Wide range of flow and pressure ratings
- Quick disassembly of core tube for easy maintenance of internal parts
- Standard disc seal made of FPM, EPDM, NBR, RUBY suitable for a wide range of operating temperatures and compatible with many fluids
- Standard manual operator allows an easy installation (1/8" version only)
- AC/DC interchangeability of the solenoid without disassembly of the valve (1/8" version only)
- UL429 and EN 60335 certified
- NSF 169 and EC 1935 / 2004 certified see "15-DIGIT PRODUCT CODE"
- Compact and low weight valve
- The solenoid valves satisfy all relevant EU and EAC directives

## General

<b>Differential pressure</b>	See «SPECIFICATIONS» [1 bar = 100 kPa]
<b>Ambient temperature range</b>	-10°C to +60°C (14°F to 140°F)
<b>Maximum viscosity</b>	40 cSt (mm <sup>2</sup> /s)
<b>Response time</b>	10 - 20 ms (1/8" version) 20 - 70 ms (1/4" version)

fluids (*)	temperature range (TS) <sup>(1)</sup>	materials (*)
air, inert gas, water, oil	0°C to +130°C (32°F to 266°F)	FPM (fluoroelastomer)
hot water and steam <sup>(2)</sup>	-10°C to +170°C (14°F to 338°F)	RUBY disc (FPM seal)
air, inert gas, water hot water and steam <sup>(2)</sup>	-10°C to +140°C (14°F to 284°F)	EPDM (ethylene propylene diene monomer)
air, inert gas, water, oil	-10°C to +90°C (14°F to 194°F)	NBR (nitrile)
refrigerating fluids	-10°C to +90°C (14°F to 194°F)	CR70N (chloroprene) (HNBR seal)

## Materials in contact with fluid

(\*) Ensure that the compatibility of the fluids in contact with the materials is verified

<b>Body</b>	Brass or stainless steel, AISI 316
<b>Shading coil</b>	Copper
<b>Core tube</b>	Stainless steel
<b>Core and plugnut</b>	Stainless steel
<b>Springs</b>	Stainless steel
<b>Seal</b>	FPM or EPDM or NBR or HNBR
<b>Disc</b>	FPM or EPDM or RUBY or NBR or CR70N
<b>Seat</b>	Brass or Stainless Steel AISI 303

## Electrical characteristics

<b>Coil insulation class</b>	F (H - approval pending)
<b>Connector</b>	Spade plug (cable Ø 6-8 mm or Ø 6-10 mm)
<b>Connector specification</b>	DIN 43650, 11 mm, industry standard B (type 01) or ISO 4400 / EN 175301-803, form A (type 02)
<b>Electrical safety</b>	IEC 335
<b>Electrical enclosure protection</b>	Moulded IP67 (EN 60529) with plug-connector
<b>Standard voltages</b>	DC (=) : 12 - 24V (+10% -5%) AC (~) : 24V/50-60 Hz - 110V/50 Hz (120 V/60Hz) 230V/50-60 Hz (+10% -15%)
<b>(Other voltages and frequencies on request)</b>	

operator ambient temperature range (TS) °C (°F)	power ratings			replacement coil			Type
	holding		hot/cold	~		=	
	(VA)	(W)	(W)	120 V/60 Hz, 110 V/50 Hz	230 V /50-60 Hz	24 V DC	
-10 to +60 (14 to 140)	4.5	3	3.5	533534-024	533534-003	533534-001	01
	-	-	5	-	-	533534-002	
	8	6	-	-	533534-023	-	
	-	-	5	-	-	533593-001	02
	14	9	9	533593-020	533593-003	533593-002	
	-	-	5.5	-	-	511952-006	

## Options

- NSF 169, EC 1935 / 2004 approval, EPDM/FPM disc and seal (Food Grade), RUBY disc, stainless steel seat
- The use of rigid sealings (RUBY) with gaseous fluids implies a slight leakage, generally limited at 2 scc/min at 1 bar pressure (0.002 l/min).

(\*) Ensure that the compatibility of the fluids in contact with the materials is verified.

<sup>(1)</sup> The minimum ambient temperature of the solenoid valve is determined by the limitations of minimum temperature indicated.

<sup>(2)</sup> Steam only for 1/4" version with stainless steel seat or body.

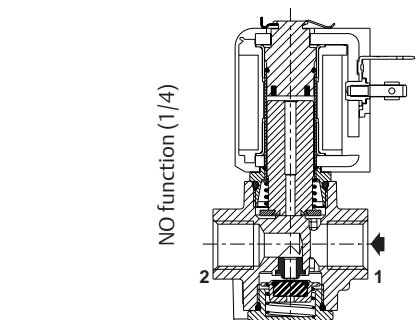
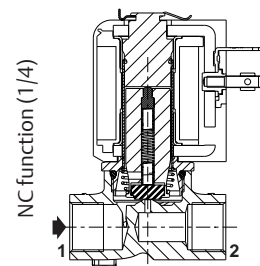
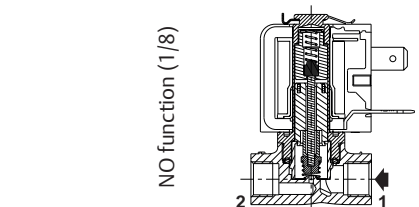
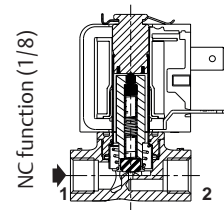
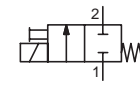
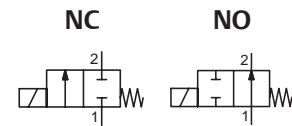

01527CB-2020/R01 Availability, design and specifications are subject to change without notice. All rights reserved.

**Specifications <sup>(1)</sup>**

Specifications <sup>(1)</sup>															15-DIGIT PRODUCT CODE															
pipe size	orifice size	flow coefficient Kv		operating pressure differential bar (psi)						power coil (W)		thread type	dimensions / type <sup>(2)</sup>	brass	stainless steel	options		voltage code												
				max. (PS)												without manual operator	with manual operator	230 V/50-60 Hz	110 V/50 Hz	120 V / 60 Hz	24 V/50-60 Hz	12 V/DC	24 V/DC							
				air (*)		water (*)		oil (*)																						
				~	=	~	=	~	=																					
mm (in)	m <sup>3</sup> /h (Cv)	(l/min)	min.	~	=	~	=	~	=																					
<b>NC - Normally closed, FPM disc and seal</b>																														
1/8	1.2 (3/64)	0.051 (0.06)	0.85	0	30 (435)	20 (290)	30 (435)	20 (290)	30 (435)	20 (290)	3	3.5	G 01	G256C134S1	G256C144S1	V00	V01	FH	F0	FQ	F3	F1								
					-	26 (377)	-	26 (377)	-	26 (377)	-	5	NPT 01	G256C149S1	G256C159S1															
	1.6 (1/16)	0.08 (0.09)	1.33	0	30 (435)	12 (174)	30 (435)	12 (174)	30 (435)	12 (174)	3	3.5	G 01	G256C135S1	G256C145S1															
					-	16 (232)	-	16 (232)	-	16 (232)	-	5	NPT 01	G256C150S1	G256C160S1															
	2 (5/64)	0.12 (0.14)	1.99	0	15 (218)	6 (87)	15 (218)	6 (87)	15 (218)	6 (87)	3	3.5	G 01	G256C136S1	G256C146S1															
					-	7 (102)	-	7 (102)	-	7 (102)	-	5	NPT 01	G256C151S1	G256C161S1															
	2.4 (3/32)	0.14 (0.16)	2.32	0	13 (189)	4 (58)	13 (189)	4 (58)	13 (189)	4 (58)	3	3.5	G 01	G256C137S1	G256C147S1															
					-	6 (87)	-	6 (87)	-	6 (87)	-	5	NPT 01	G256C152S1	G256C162S1															
	3.2 (1/8)	0.18 (0.21)	2.99	0	7 (102)	2 (29)	7 (102)	2 (29)	7 (102)	2 (29)	3	3.5	G 01	G256C138S1	G256C148S1															
					-	3 (44)	-	3 (44)	-	3 (44)	-	5	NPT 01	G256C153S1	G256C163S1															
	1/4 <sup>(3)</sup>	1.6 (1/16)	0.10 (0.11)	1.59	0	30 (435)	30 (435)	30 (435)	30 (435)	30 (435)	30 (435)	-	5	G* 02	G256C102S1								G256C111S1	V00	-	FH	F0	FQ	F3	F1
						-	18 (261)	-	18 (261)	-	18 (261)	-	5	NPT 02	G256C104S1								G256C113S1							
2.4 (3/32)		0.18 (0.21)	2.99	0	20 (290)	20 (290)	20 (290)	20 (290)	20 (290)	20 (290)	9	9	G* 02	G256C121S1	G256C129S1															
					-	6 (87)	-	6 (87)	-	6 (87)	-	5	NPT 02	G256C106S1	G256C115S1															
3.2 (1/8)		0.30 (0.35)	5.03	0	15 (218)	12 (174)	15 (218)	12 (174)	15 (218)	12 (174)	9	9	G* 02	G256C123S1	G256C131S1															
					-	3 (44)	-	3 (44)	-	3 (44)	-	5	NPT 02	G256C107S1	G256C116S1															
4.5 (11/64)		0.40 (0.46)	6.64	0	8 (116)	6 (87)	8 (116)	6 (87)	8 (116)	6 (87)	9	9	G* 02	G256C124S1	G256C132S1															
					-	2 (29)	-	2 (29)	-	2 (29)	-	5	NPT 02	G256C108S1	G256C117S1															
5 (13/64)		0.48 (0.55)	7.92	0	5 (73)	4 (58)	5 (73)	4 (58)	5 (73)	4 (58)	9	9	G* 02	G256C125S1	G256C133S1															
					-	3 (44)	-	3 (44)	-	3 (44)	-	5	NPT 02	G256C107S1	G256C116S1															

<sup>(1)</sup> All performances are referred to Ambient Temperature = +60°C.  
<sup>(2)</sup> For dimensions, see drawing(s) for each construction type on the following page(s).  
<sup>(3)</sup> Steam: . RUBY Sealing PS max. 8 bar (max. temperature of fluid 170°C)  
 . EPDM Sealing PS max. 4 bar (max. temperature of fluid 140°C)  
 . FPM Sealing PS max. 2.8 bar (max. temperature of fluid 130°C)  
 (\*) Ensure that the compatibility of the fluids in contact with the materials is verified.

## Specifications <sup>(1)</sup>

														15-DIGIT PRODUCT CODE								
pipe size	orifice size	flow coefficient Kv		operating pressure differential bar (psi)						power coil (W)		thread type	dimensions / type <sup>(2)</sup>	brass	stainless steel	options		voltage code				
				max. (PS)												without manual operator	with manual operator	230 V/50-60 Hz	110 V/50 Hz (120 V / 60 Hz)	24 V/50-60 Hz	12 V/DC	24 V/DC
				air (*)		water (*)		oil (*)														
				min.	~	=	~	=	~													
<b>NO - Normally open, FPM disc and seal</b>																						
1/8	1.2 (3/64)	0.05 (0.06)	0.85	0	17 (247)	-	17 (247)	-	17 (247)	-	6	-	G 01	G256C230S1	G256C242S1	V00	-	FH	F0	FQ	F3	F1
		NPT 01	8256C230S1	8256C242S1																		
		0.05 (0.06)	0.83	0	-	17 (247)	-	17 (247)	-	17 (247)	-	5.5	G 03	G256C246S1	G256C250S1							
		NPT 03	8256C246S1	8256C250S1																		
	1.6 (1/16)	0.08 (0.09)	1.33	17 (247)	-	17 (247)	-	17 (247)	-	6	-	G 01	G256C231S1	G256C243S1								
				NPT 01	8256C231S1	8256C243S1																
		0	-	10 (145)	-	10 (145)	-	10 (145)	-	5.5	G 03	G256C247S1	G256C251S1									
		NPT 03	8256C247S1	8256C251S1																		
<b>NO - Normally open, FPM disc and seal, stainless steel seat</b>																						
1/4 <sup>(3)</sup>	3.2 (1/8)	0.3 (0.35)	5.0	0	4 (58)	4 (58)	4 (58)	9	9	G 02	G256C216S1	-	9DQ	-	FH	F0	FQ	F3	F1			
					NPT 02	8256C216S1	-															
<b>NO - Normally open, FPM disc and seal (Food Grade), stainless steel seat + NFS + EC 1935 / 2004</b>																						
1/4 <sup>(3)</sup>	3.2 (1/8)	0.3 (0.35)	5.0	0	4 (58)	4 (58)	4 (58)	9	9	G 02	G256C216S1	-	9DH	-	FH	F0	FQ	F3	F1			
					NPT 02	8256C216S1	-															

<sup>(1)</sup> All performances are referred to Ambient Temperature = +60°C.

<sup>(2)</sup> For dimensions, see drawing(s) for each construction type on the following page(s).

<sup>(3)</sup> Steam: FPM Sealing PS max. 2.8 bar (max. temperature of fluid 130°C)

(\*) Ensure that the compatibility of the fluids in contact with the materials is verified.

**Product selection guide**

Configurator - CAD Files

**PRODUCT CODE**

**G 256 C 134 S1 V00 F1**

**Connection Type**  
G = ISO 228/1 (1/8" or 1/4")  
8 = NPT (SAE 71051)

**Product series**  
256

**Revision letter**  
C = Initial release

**Valves version** <sup>(2)</sup>

**Electrical interface**  
S1 = With spade plug connector  
S0 = Without spade plug connector  
L0 = Leaded coil (1/8" - 1/4", 500 mm cable length)

<sup>(2)</sup> 1/8" NC, coil size 30, please contact us to obtain catalogue numbers available and technical information.

**Voltage**  
F1 = 24 V DC Class F  
F3 = 12 V DC Class F  
FQ = 24 V / 50-60 Hz Class F  
F0 = 110 V / 50 Hz (120 V / 60 Hz) Class F  
FH = 230 V / 50-60 Hz Class F  
ET = 220-230 V / 50 Hz 208-240 V / 60 Hz Class F <sup>(1)</sup>  
H1 = 24 V DC Class H  
HH = 230 V / 50-60 Hz Class H

**Options**  
**Without manual operator**  
E00 = EPDM Disc and Seal  
V00 = FPM Disc and Seal  
N00 = NBR Disc and Seal  
J00 = CR70N Disc (HNBR Seal) <sup>(3)</sup>  
X00 = RUBY Disc (FPM Seal) <sup>(3)(1)</sup>  
9CJ = RUBY Disc (FPM Seal) + NSF + EC 1935 / 2004 <sup>(3)(1)</sup>  
9CK = EPDM Disc and Seal (Food Grade) + NSF + EC 1935 / 2004 <sup>(4)</sup>  
9CM = FPM Disc and Seal (Food Grade) + NSF + EC 1935 / 2004  
9DF = EPDM Disc and Seal (Food Grade) + Stainless Steel Seat + NSF + EC 1935 / 2004 <sup>(3)</sup>  
9DH = FPM Disc and Seal (Food Grade) + Stainless Steel Seat + NFS + EC 1935 / 2004 <sup>(3)</sup>  
9DP = EPDM Disc and Seal + Stainless Steel Seat <sup>(3)</sup>  
9DQ = FPM Disc and Seal + Stainless Steel Seat <sup>(3)</sup>  
9DY = RUBY Disc (FPM Seal) + Stainless Steel Seat <sup>(3)(1)</sup>  
9ED = RUBY Disc (FPM Seal) + Stainless Steel Seat + NSF + EC 1935 / 2004 <sup>(3)(1)</sup>

**With manual operator** <sup>(5)</sup>  
(With maintained manual operator)  
E01 = EPDM Disc and Seal, w/ Manual Operator  
V01 = FPM Disc and Seal, w/ Manual Operator  
N01 = NBR Disc and Seal, w/ Manual Operator  
9CE = EPDM Disc and Seal (Food Grade), w/ Manual Operator + NSF + EC 1935 / 2004  
9CW = FPM Disc and Seal (Food Grade), w/ Manual Operator + NSF + EC 1935 / 2004

<sup>(1)</sup> To obtain the correct pressure rating and power absorption check the landing pages of the online configurator. Operating Voltage Range (+10% -10%).  
<sup>(3)</sup> Only for 1/4" Version.  
<sup>(4)</sup> Not available for NO Version.  
<sup>(5)</sup> Not available for 1/4" Version.

Repair Kits and Service Parts - Spare Parts Kits

Spare parts kits no. (*)														
		EPDM Disc and Seal	FPM Disc and Seal	NBR Disc and Seal	-	-	-	-	-	-	-	-	-	
<b>NC - Normally closed - 1/4" - AC (~)</b>														
256C119/121/123/ 124/125/127/129/ 129/131/132/133	M200706	E00	V00	N00	-	-	-	-	-	-	-	-	-	
<b>NC - Normally closed - 1/4" - DC (=)</b>														
256C119/121/123/ 124/125/127/129/ 129/131/132/133	M200714	E00	V00	N00	-	-	-	-	-	-	-	-	-	
<b>NO - Normally open - 1/4" - AC (~) / DC (=)</b>														
256C216	M200716	-	-	-	-	-	-	-	-	-	-	-	-	
		EPDM Disc and Seal (Food Grade) + NSF + EC 1935 / 2004 + Stainless Steel Seat	FPM Disc and Seal (Food Grade) + NSF + EC 1935 / 2004 + Stainless Steel Seat	RUBY Disc (FPM Seal) + Stainless Steel Seat + NSF + EC 1935 / 2004	-	-	RUBY Disc (FPM Seal) + NSF + EC 1935 / 2004	EPDM Disc and Seal (Food Grade) + NSF + EC 1935 / 2004	FPM Disc and Seal (Food Grade) + NSF + EC 1935 / 2004	EPDM Disc and Seal + Stainless Steel Seat	FPM Disc and Seal + Stainless Steel Seat	RUBY Disc (FPM Seal) + Stainless Steel Seat	CR70N Disc (HNBR Seal)	RUBY Disc (FPM Seal)
<b>NC - Normally closed - 1/4" - AC (~)</b>														
256C119/121/123/ 124/125/127/129/ 129/131/132/133	M200706	9DF	9DH	-	-	-	-	9CK	9CM	9DP	9DQ	-	J00	X00
256C106/107/115/ 116/123/124/131/ 132	M200707	-	-	9ED	-	-	9CJ	-	-	-	-	9DY	-	-
<b>NC - Normally closed - 1/4" - DC (=)</b>														
256C119/121/123/ 124/125/127/129/ 129/131/132/133	M200714	9DF	9DH	-	-	-	-	9CK	9CM	9DP	9DQ	-	J00	X00
256C106/107/115/ 116/123/124/131/ 132	M200715	-	-	9ED	-	-	9CJ	-	-	-	-	9DY	-	-
<b>NO - Normally open - 1/4" - AC (~) / DC (=)</b>														
256C216	M200716	-	9DH	-	-	-	-	-	-	-	9DQ	-	-	-

01527GB-2020/R01  
Availability, design and specifications are subject to change without notice. All rights reserved.

**Installation**

- The solenoid valves can be mounted in any position without affecting operation
- Solenoid valves have 2 mounting holes in body
- Thread connection “G” applicable for 1/8, have standard thread according to ISO 228/1
- Thread connection “8” have standard thread = NPT (SAE 71051)
- Installation/maintenance instructions are included with each valve

**Dimensions mm (inches), Weight kg (Lbs)**

Configurator - CAD Files



**TYPE 01**  
Electrical interface “S1”  
Coil size 20 mm - Thermoplastic moulded  
IEC 335 / DIN 43650  
IP67

NC (1/8”): 256C134 to163

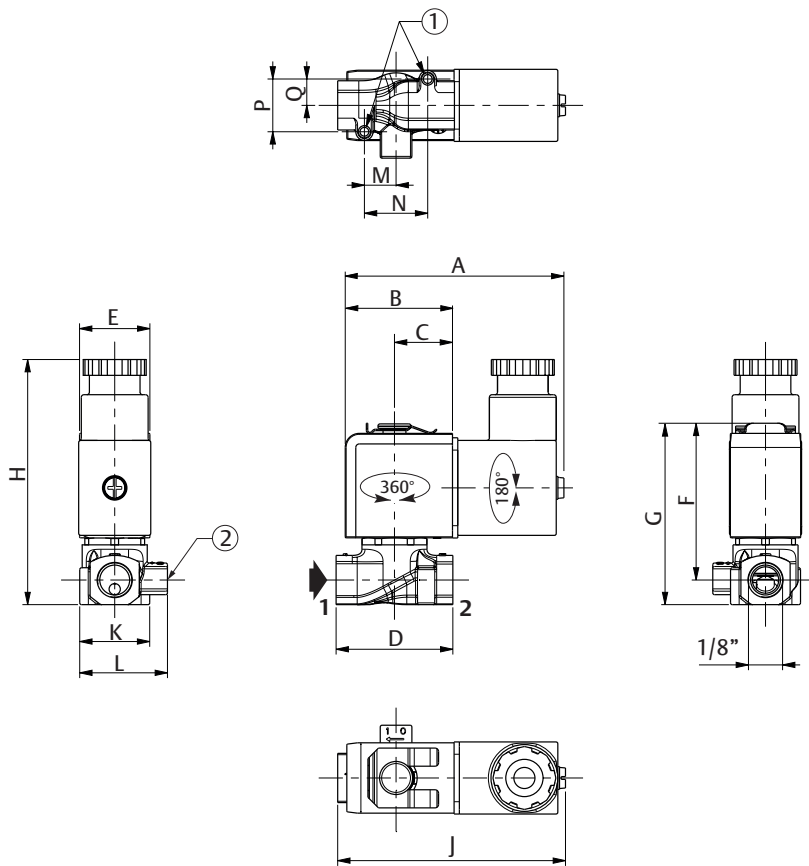

- ① 2 mounting holes:  
M3 dia., through holes (0.12 inch dia.)
- ② Manual operator location

size 20		A	B	C	D	E	F	G	H	J	K	L	M	N	P	Q	weight <sup>(1)</sup>	
G256C134..G256C163	mm	61.9	30.5	16.5	33.2	20	44.6	54.9	69.7	64.8	19.9	24.95	9	18	15	7.5	0.116	kg
8256C134..8256C163	(in)	2.44	1.20	0.65	1.31	0.79	1.76	2.16	2.74	2.55	0.78	0.98	0.35	0.71	0.59	0.30	0.2556	(Lbs)

<sup>(1)</sup> Incl. coil(s) and connector(s).

## Dimensions mm (inches), Weight kg (Lbs)

Configurator - CAD Files

NO (1/8"): 256C230 to 245

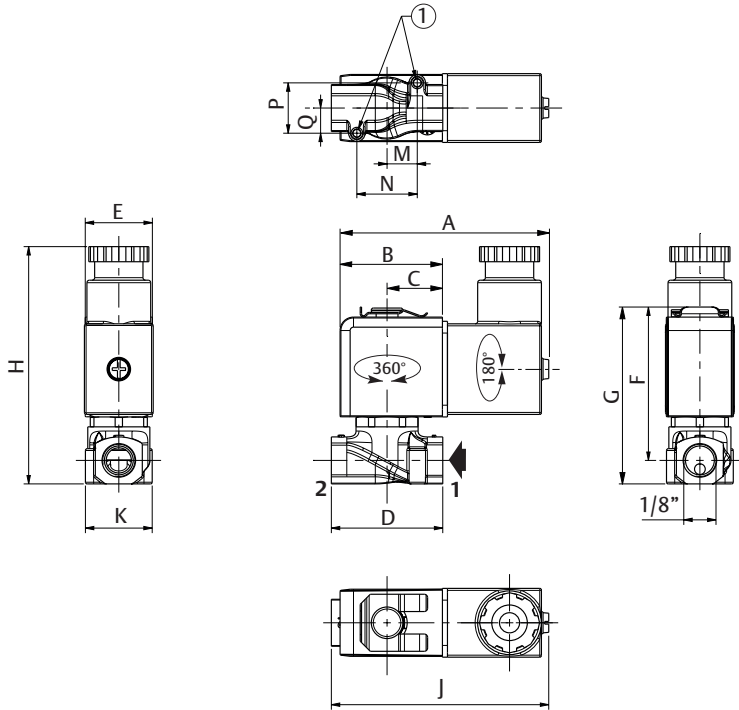

① 2 mounting holes:  
M3 dia., through holes (0.12 inch dia.)

size 20		A	B	C	D	E	F	G	H	J	K	M	N	P	Q	weight <sup>(1)</sup>	
G256C122..G256C245	mm	61.9	30.5	16.5	33.2	20	45.7	54.9	70.7	64.8	19.9	9	18	15	7.5	0.116	kg
8256C122..8256C245	(in)	2.44	1.20	0.65	1.31	0.79	1.8	2.16	2.78	2.55	0.78	0.35	0.71	0.59	0.30	0.255	(Lbs)

<sup>(1)</sup> Incl. coil(s) and connector(s).

**Dimensions mm (inches), Weight kg (Lbs)** 

Configurator - CAD Files



**TYPE 02**

Electrical interface "S1"

Coil size 30 mm - Thermoplastic moulded

IEC 335 / ISO 4400

IP67

NC (1/4"): 256C102 to 133

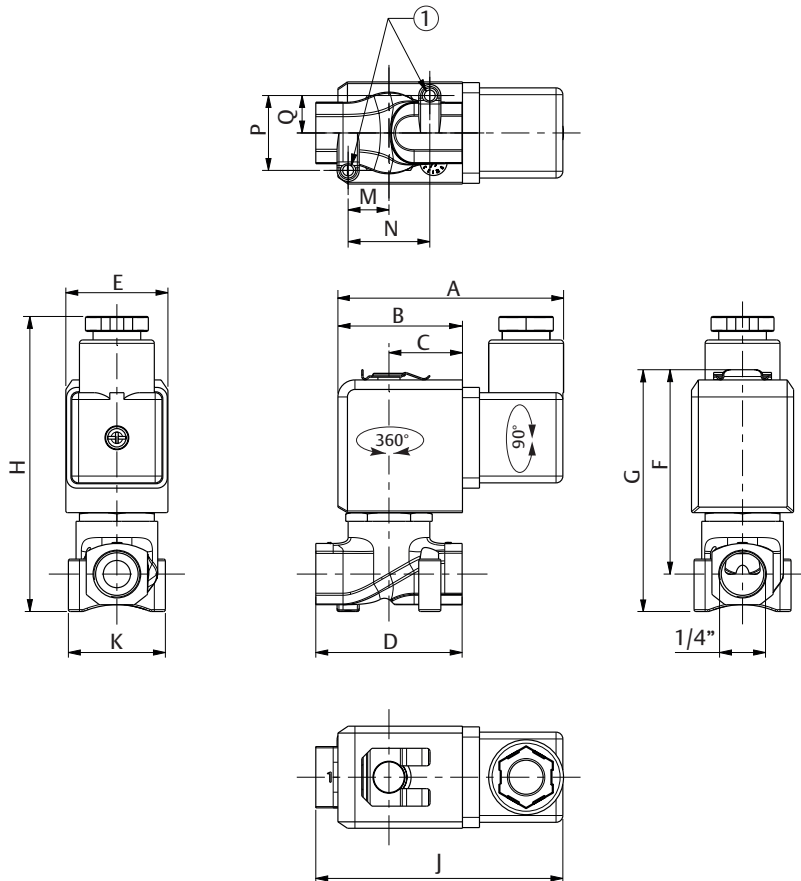

- ① 2 mounting holes:  
M4 dia., through holes (0.16 inch dia.)

size 30		A	B	C	D	E	F	G	H	J	K	M	N	P	Q	weight <sup>(1)</sup>	
G256C100..G256C133	mm	66.3	36.6	21.6	43	30	60	70.5	86.7	72.6	28.5	12	24	22	11	0.3	kg
8256C100..8256C133	(in)	2.61	1.44	0.85	1.69	1.18	2.36	2.78	3.40	2.86	1.12	0.47	0.94	0.87	0.43	0.661	(Lbs)

<sup>(1)</sup> Incl. coil(s) and connector(s).



Dimensions mm (inches), Weight kg (Lbs)

Configurator - CAD Files

NO (1/4"): 256C201 to 221

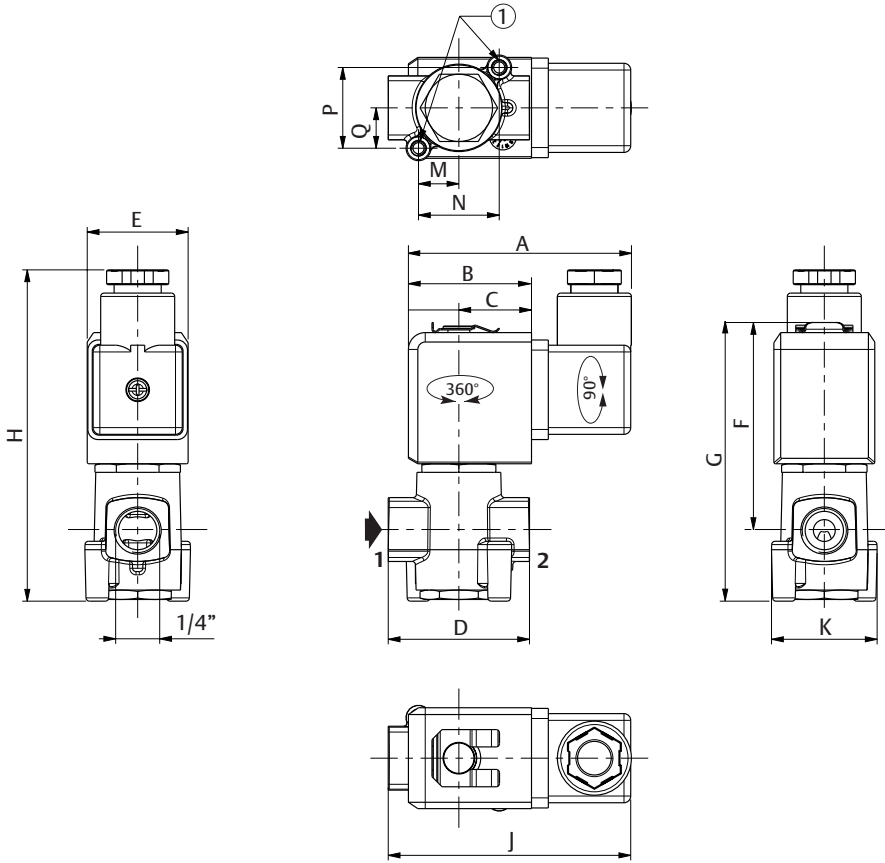

① 2 mounting holes:  
M4 dia., depth 8 mm (0.16 inch dia., depth 0.31 inch)

size 30		A	B	C	D	E	F	G	H	J	K	M	N	P	Q	weight <sup>(1)</sup>	
G256C200..G256C221	mm	66.3	36.6	21.6	42	30	61.6	84.4	98.5	72.1	31.4	12	24	24	12	0.34	kg
8256C200..8256C221	(in)	2.61	1.44	0.85	1.65	1.18	2.42	3.32	3.88	2.80	1.24	0.47	9.94	0.94	0.47	0.75	(Lbs)

<sup>(1)</sup> Incl. coil(s) and connector(s).

01527GB-2020/R01  
Availability, design and specifications are subject to change without notice. All rights reserved.

**Dimensions mm (inches), Weight kg (Lbs)**

Configurator - CAD Files



**TYPE 03**  
Electrical interface "S1"  
Coil size 30 mm - Thermoplastic moulded  
IEC 335 / ISO 4400  
IP67

NO (1/8"): 256C246 to 253

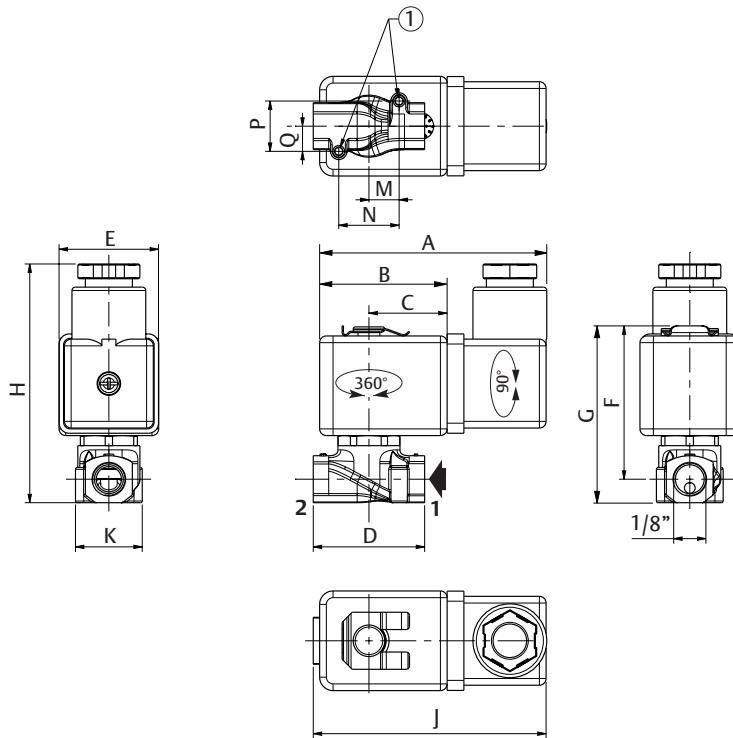

① 2 mounting holes:  
M3 dia., through holes (0.12 inch dia.)

size 30		A	B	C	D	E	F	G	H	J	K	M	N	P	Q	weight <sup>(1)</sup>	
G256C246..G256C253	mm	67.7	38	23.3	33.2	29.7	45.7	52.7	71.2	69.4	19.9	9	18	15	7.5	0.20	kg
8256C246..8256C253	(in)	2.66	1.49	0.92	1.31	1.18	1.8	2.07	2.8	2.73	0.79	0.35	0.70	0.59	0.29	0.44	(Lbs)

<sup>(1)</sup> Incl. coil(s) and connector(s).

01527GB-2020/R01  
Availability, design and specifications are subject to change without notice. All rights reserved.